

# AIR LIFT

INSTRUCTIONS • PARTS DRAWING • PARTS LIST

## ML - 1000A ML - 1000AC

WARNING: READ INSTRUCTIONS BEFORE OPERATING

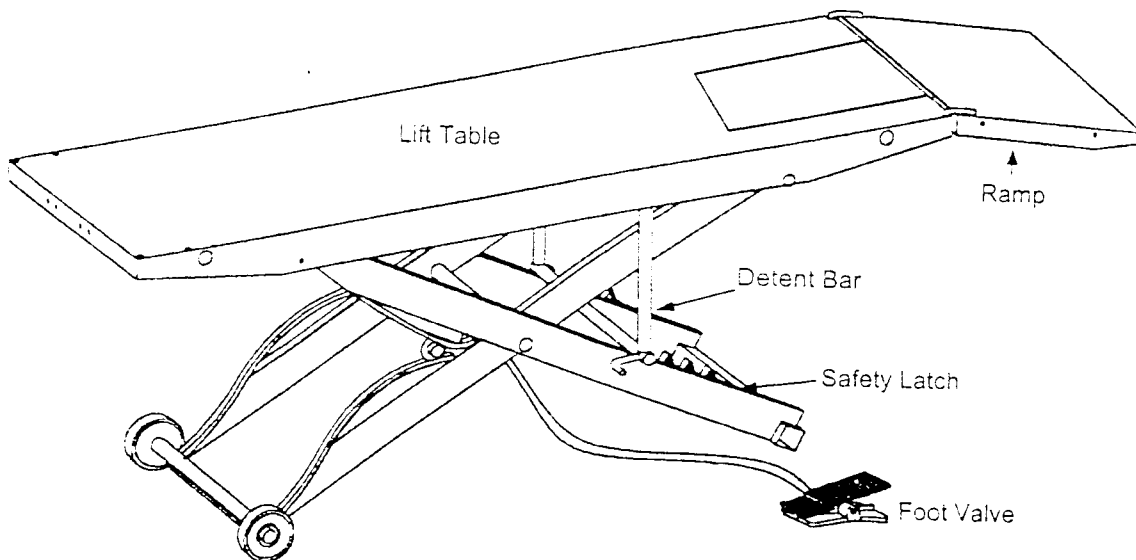

1. Center load on table - 1000 lb. maximum.
2. Connect to 100 psi maximum shop air.
3. Keep safety bar in position at all times - except when lowering.
4. Keep hands and tools from under carriage.
5. Do not mount table when in elevated position.
6. Do not ride vehicle onto lift.
7. Lift must be in the lowered position when moving.
8. Only trained persons should operate Air Lift.
9. The working area should be sufficiently lit.
10. Foot controller should be at least 3 feet away from Air Lift during raising and lowering operation.
11. Lift is recommended for indoor use only.

# AIR LIFT



**NOTE: READ ENTIRE MANUAL TO COMPLY WITH ALL SAFETY AND SERVICE PRECAUTIONS. DEATH, PERSONAL INJURY AND/OR PROPERTY DAMAGE MAY OCCUR UNLESS INSTRUCTIONS ARE FOLLOWED CAREFULLY.**

## INSTRUCTIONS

### UNPACKING AND SET-UP

Open carton, then remove ramp, and shipping boards.



- Connect foot-operated air valve to 100 psi air supply. The lift may be damaged and/or personal injury may result if the pressure exceeds the maximum 100 psi rating. Stand clear of lift table, and depress the UP side of foot valve to raise table. To lower table, lift detent bar from safety latch and lower to next position or to floor. Insert ramp mounting pins into holes at either end of table to mount ramp.
- NOTE:** If cycle vise is being installed, ramp must be mounted opposite the cycle vise.

### OPERATION



1. Loads must be centered on table at all times.
2. Loads must be firmly positioned and secured on table at all times.
3. All moving parts have been lubricated at the factory and should be re-lubricated every (6) months to prevent galling. Grease zerks are located at each end of frame pivot shaft and at top ends of inside frame assembly.
4. Lightly oil cylinder rod when it becomes dry.
5. Squirt some oil through air bleed hole in plate end of cylinder to lubricate piston and its seal every (6) months.
6. Pivot shaft set screws should be checked frequently to be sure they are tight. These are located at the top end of the inside frame assembly.

### OTHER OPTIONS AVAILABLE

Separate installation instructions included with each option.

PART #	DESCRIPTION
3612P01	FRONT EXTENSION - Extends lift top to 93" for longer wheel base motorcycles
3612P02	FRONT CYCLE VISE - Used to stabilize motorcycle while on lift
3612P03	SIDE EXTENSION SET - Expands width of lift from 24" to 48" includes stabilizer bar

# 3612P03 12" SIDE EXTENSION ( for ML-1000A, ML-1000AC )

## Installation Instructions

### MOUNTING INSTRUCTIONS

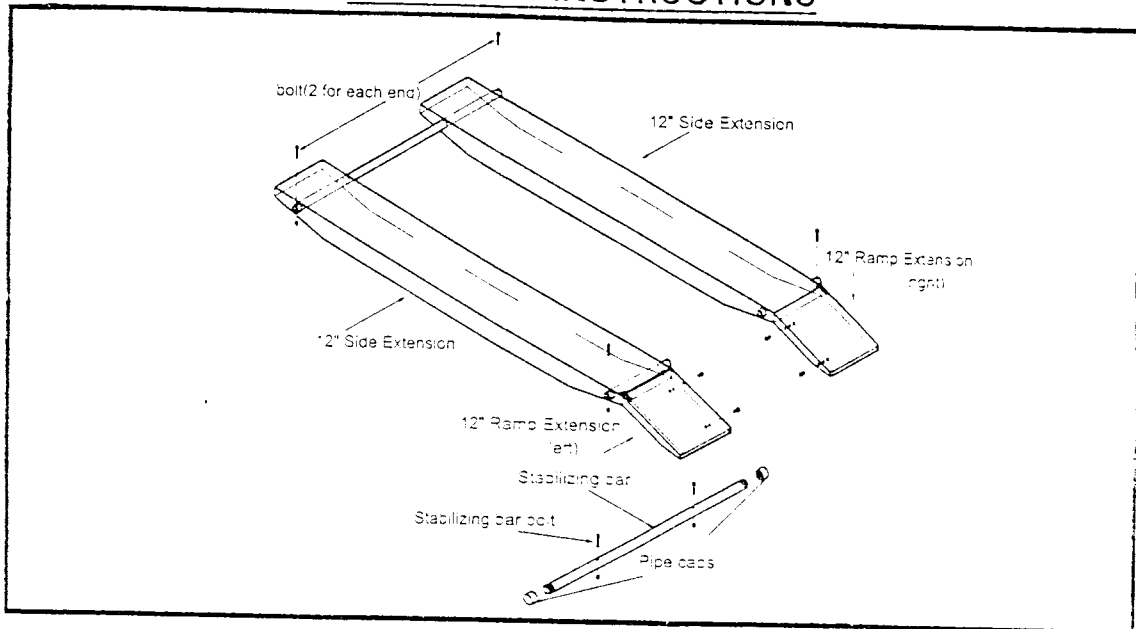

1. Insert pipes from extension panel package through holes in lift table.
2. Mount panels on ends of pipe on each side of table. With ramp hole to outside.
3. Insert M8 BOLT provided through holes in each end of pipe.
4. Secure ramp extensions to ramp with bolts provided. Make sure ramp hooks are positioned on the outside.
5. **Stabilization bar directions** - Unscrew cap from one of the ends of the stabilization pipe. Insert bolt in drilled out hole and tighten with nut. Slide pipe through the stationary square tubing on the lift legs. Insert the other bolt, tighten down with nut. Put on the other cap and tighten.

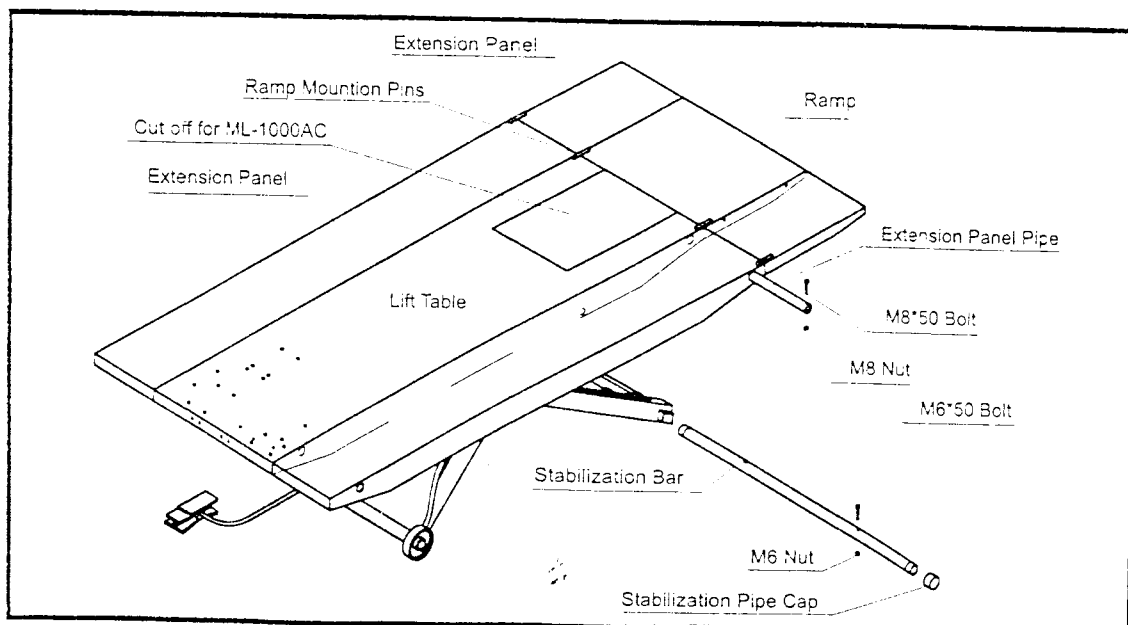

# 3612P02 Cycle Vise

( for ML-1000A, ML-1000AC )

## Installation Instructions

The 3612P02 Cycle Vise mounts directly onto the Air Lift.

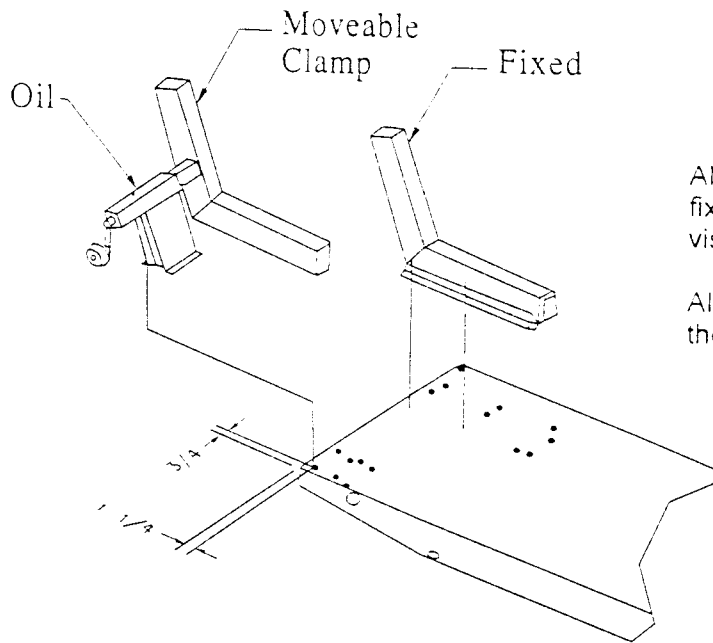

Align two inside hole of the fixed clamp over the existing vise hole pattern as shown.

Align the moveable clamp with the locating corner hole.

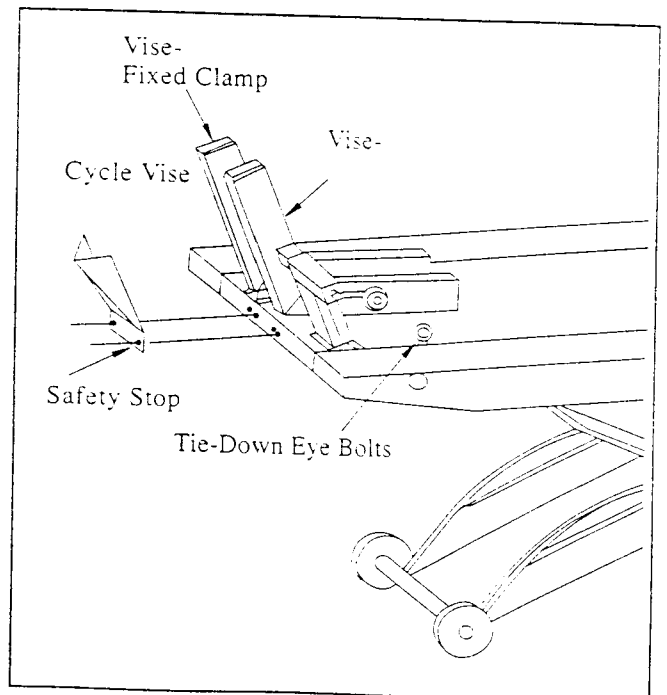
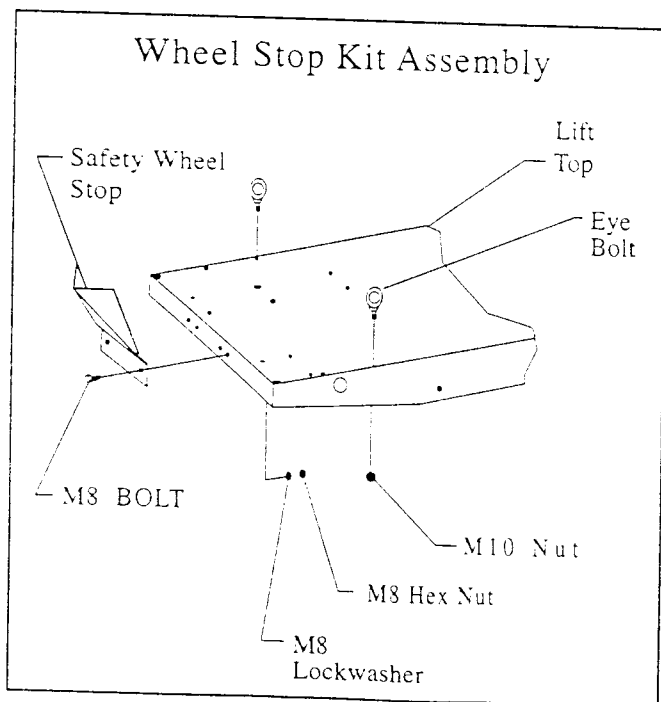

# 3612P01 13" FRONT EXTENSION ( for ML-1000A, ML-1000AC )

## Installation Instructions

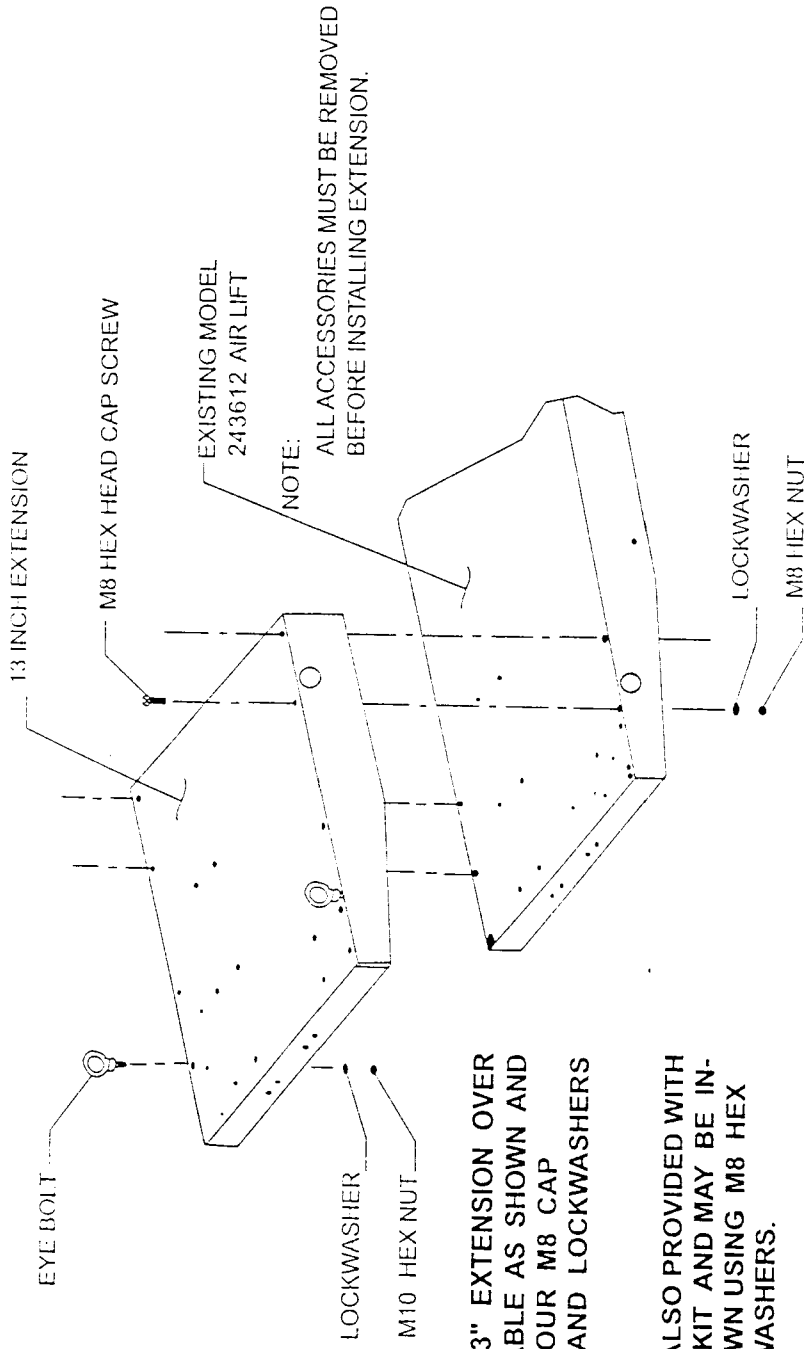

POSITION THE 13" EXTENSION OVER THE EXISTING TABLE AS SHOWN AND ATTACH WITH FOUR M8 CAP SCREWS, NUTS AND LOCKWASHERS PROVIDED.

EYE BOLTS ARE ALSO PROVIDED WITH THE EXTENSION KIT AND MAY BE INSTALLED AS SHOWN USING M8 HEX NUTS AND LOCKWASHERS.

# AIR LIFT

## REPLACEMENT PARTS

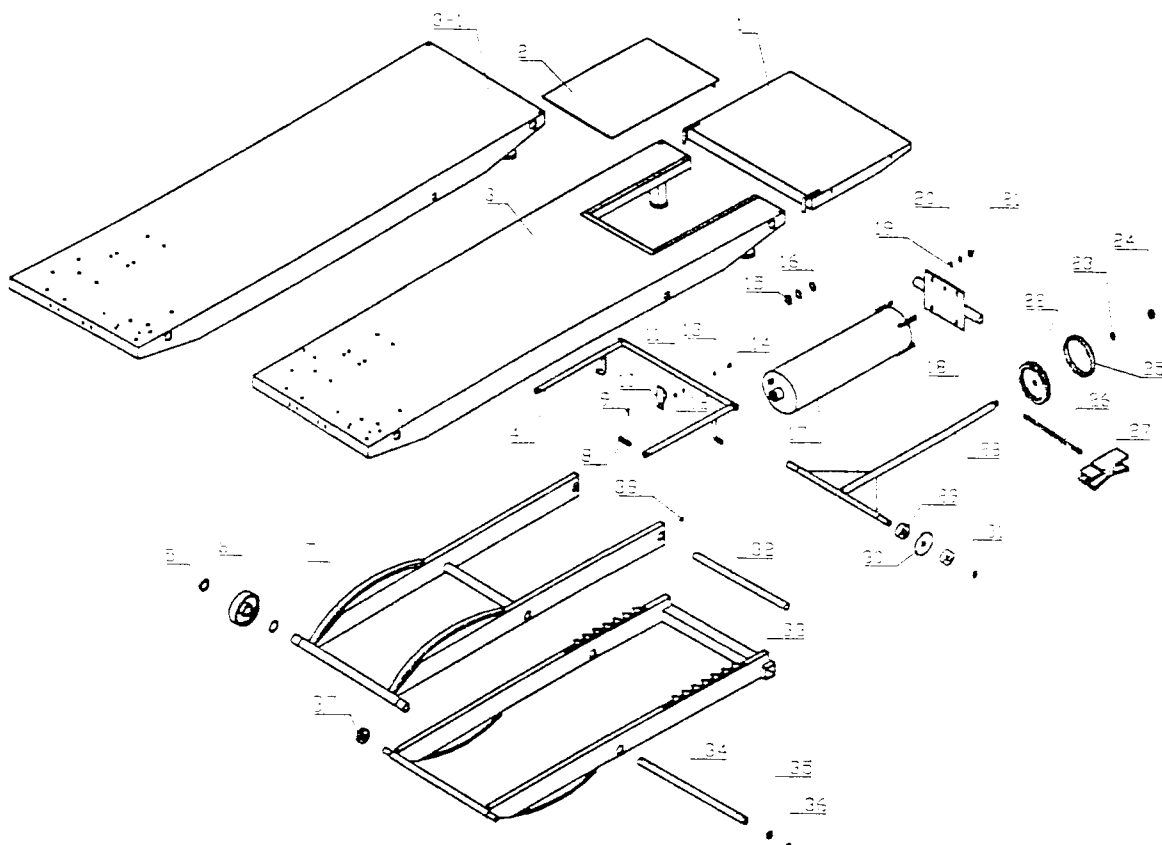

No.	Description	Qty	No.	Description	Qty	No.	Description	Qty
1	Ramp	1	13	Lock Washer	1	26	Valve Hose W / Fitting	1
2	Drop Out Cover	1	14	Screw	1	27	Foot Valve Assembly	1
3	Top Assembly	1	15	Wiper Ring	1	28	Cylinder Shaft Assembly	1
3-1	Top Assembly	1	16	O-ring	2	29	Cam Roller Bearing	4
4	Detent Bar	1	17	Cylinder	1	30	Cam Bearing Space	2
5	Retaining Ring	4	18	Cylinder End Plate	1	31	Retain Ring	2
6	Wheel	2	19	Washer	4	32	Cylinder Pivot Shaft	1
7	Stand	1	20	Lock Washer	4	33	Stand	1
8	Clevis Pin	2	21	Nut	4	34	Frame Pivct Shaft	1
9	Cotter Pin	2	22	Piston	1	35	Retaining Ring	2
10	Detent Clip	1	23	O-ring	1	36	Oil Cup	4
11	Nut	1	24	Nut	1	37	Track Roller Bearing	2
12	Washer	1	25	Piston Seal	1	38	Screw	2