

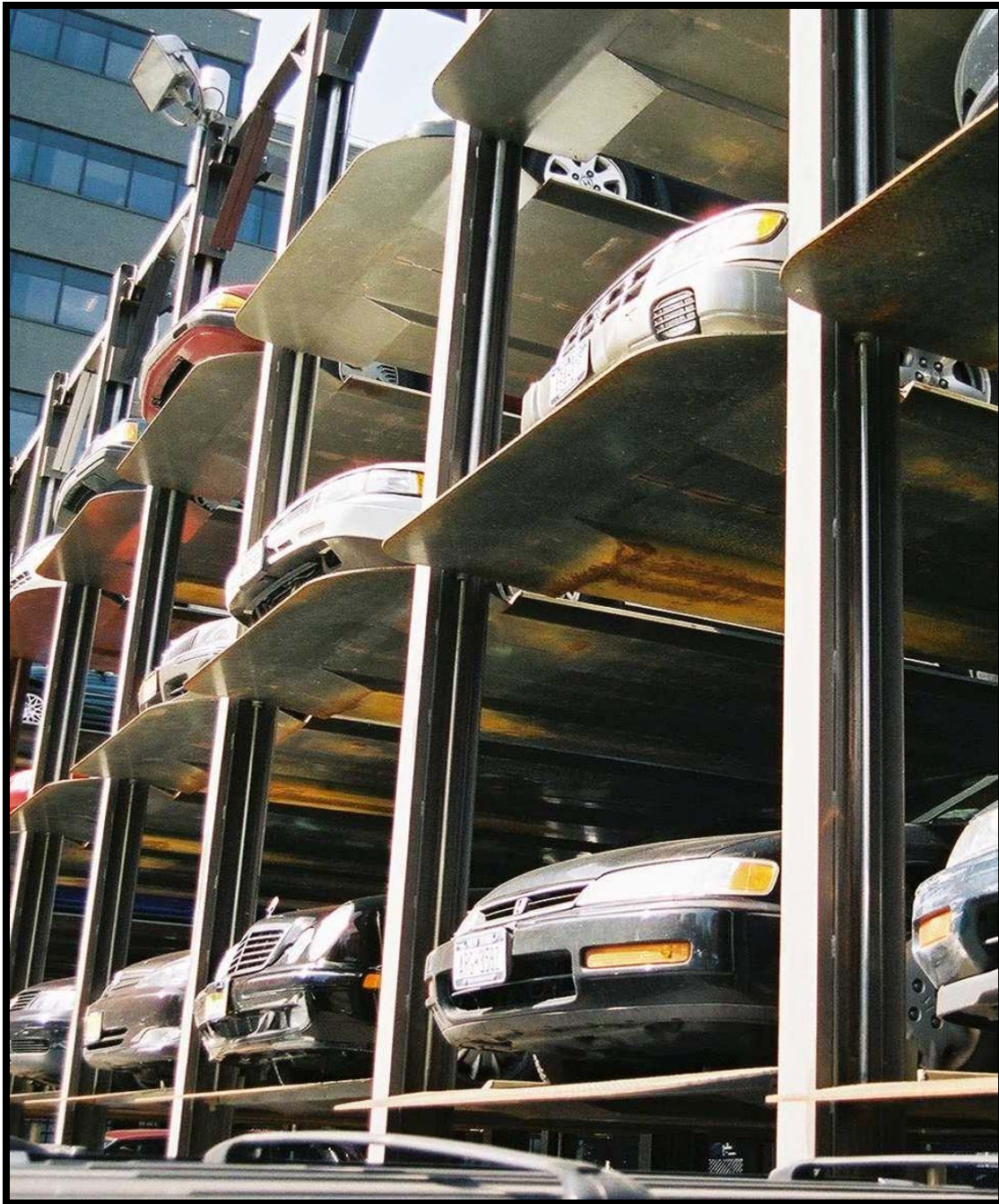

**HARDING**  
**STEEL**

## Harding Steel Tri-Lift



**World Class Lifts since 1968**



**HARDING  
STEEL**

## Harding Steel Tri-Lift



Density

Security

Economy





**HARDING  
STEEL**

## Tri-Lift System Description

**System Description:** The Harding Steel Tri-Lift parking system is a 4-post integrated parking lift designed for rugged indoor or outdoor operation. Each system may be configured as a stand-alone lift or combined into rows of lifts, with each pair of machines sharing a common set of posts. Each parking level of the lift is an all-steel **galvanized** platform that will accommodate vehicles weighing up to 6000 pounds with overall heights of approximately 75". Each vehicle platform is raised and lowered by a series of cables attached to the four corners of each platform. A hydraulic cylinder on each machine controls the raising and lowering of the platforms. Lifts are operated by a trained attendant who must be present at the control switch of each lift during operation. Lifts are equipped with steel locking mechanisms that provide safety to both vehicles and personnel.

**Hydraulic Power System:** Lifts are powered by an integrated power pack that consists of an electrical control panel, hydraulic pump motor, and hydraulic fluid tank. Power packs are sized to the specific application. Each power pack can operate up to 20 lifts depending on configuration, layout, and other technical factors. Power pack units each require their own dedicated 220V, 40 amp, 3-phase power circuit. Fluid tanks are equipped with electric heaters.

**Applications:** Tri-Lifts are ideal for applications that require high density vehicle parking and storage. These lifts are employed all over the world in applications that include commercial parking, retail auto dealerships, classic car storage, residential parking, office parking, rental car agencies, and auto repair/service.



- Commercial parking
- Vehicle storage
- Auto retail and service
- Residential - multi family
- High security environments
- Rental car agencies
- Fabricated in the USA
- All US hydraulic components





**HARDING**  
**STEEL**



- Hot dipped galvanized vehicle platforms now standard
- Seismic Zone 4 approved
- Two-position fail-safe locking mechanism
- Custom enamel finishes for columns and beams





**HARDING**  
**STEEL**

## Tri-Lift System Dimensions (Wide Unit Shown)

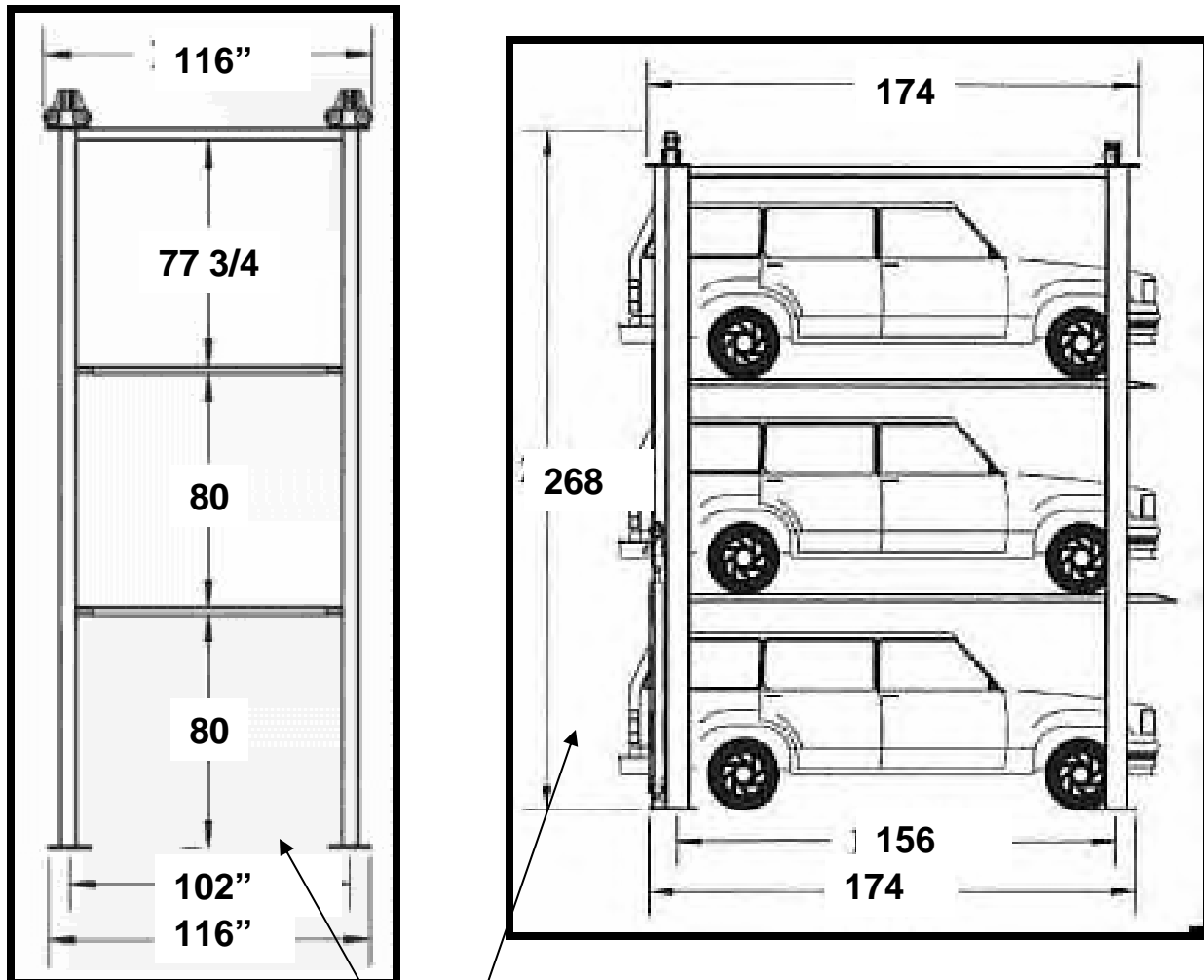

Heights of overall machine and individual stall heights may be customized by application

\* Triple high units are now available in a 8' 6" wide model



**HARDING**  
**STEEL**

## Tri-Lift System (wide) Footprint Dimensions ("8' 6" - Product)

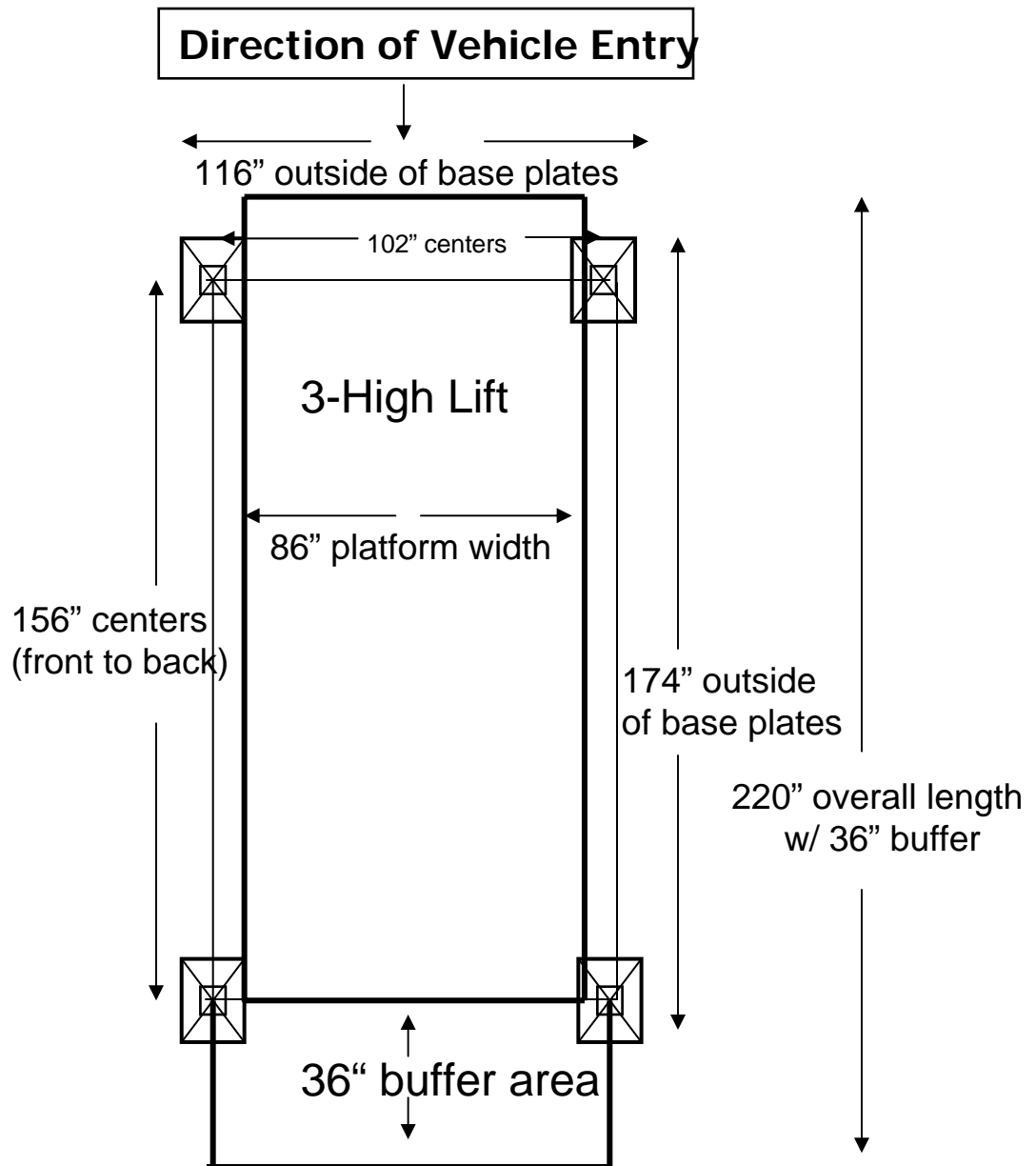



**HARDING**  
**STEEL**

## Tri-Lift System (standard) Footprint Dimensions ("8-Foot" Product\*)

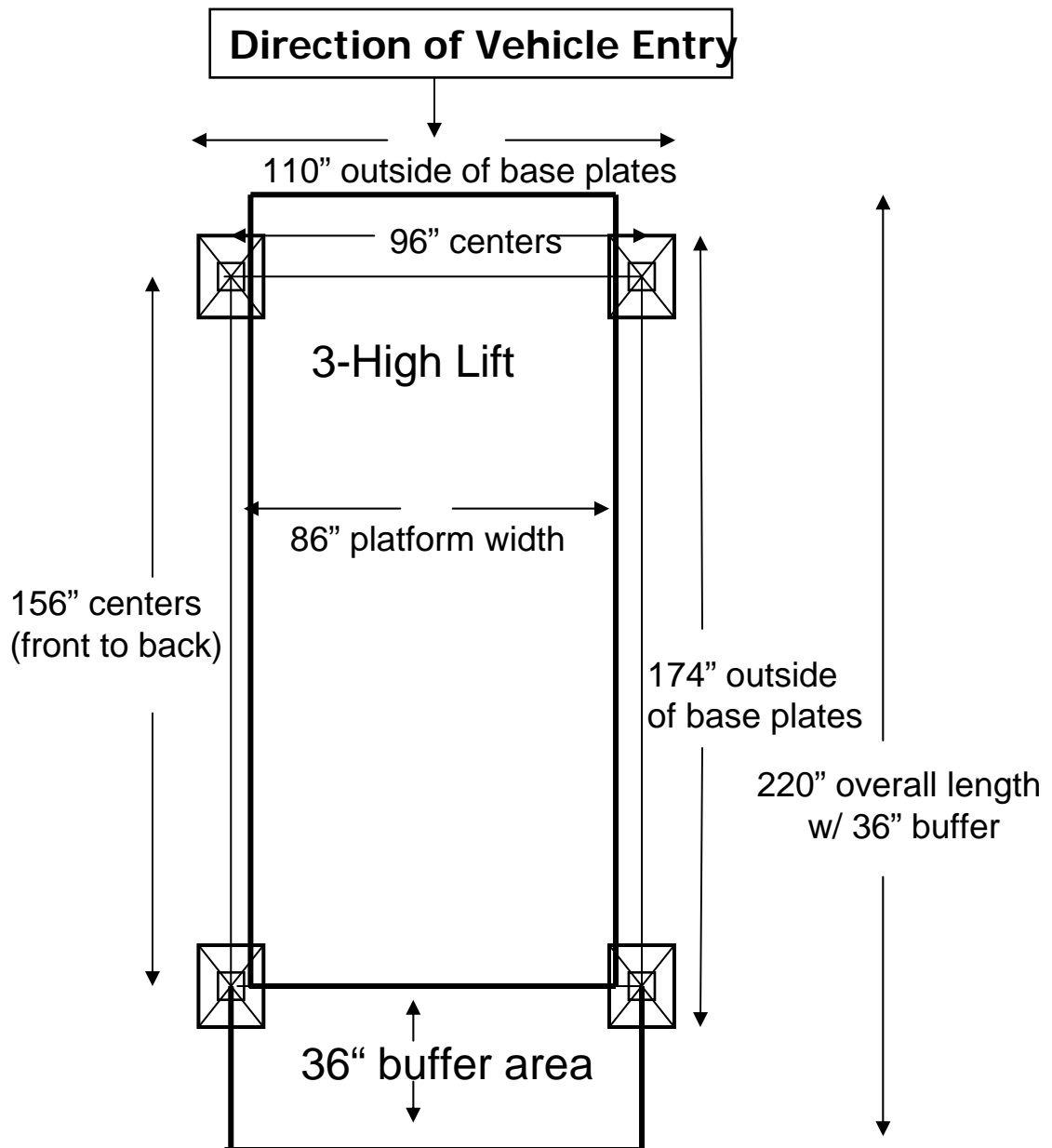

• Triple high units are also available in a 8' 6" wide model (102" centers)



**HARDING**  
**STEEL**

## Individual Lift Operation

Toggle Switches or Push Button/ Key Locks are Available





## Tri-Lift System Specifications and Site Requirements

- **Capacity:** the maximum lifting capacity is twelve thousand (12,000) pounds. Platforms are rated at six thousand (6,000) pounds each.
- **Site requirements:**
  - Lifts can be installed as single units, or in rows, sharing common posts between units.
  - Surface must be level to within 2 inches per 8 feet (side-to-side or front-to-back).
  - Surface under lifts should be standard commercial grade, 3000 psi reinforced concrete at least 6" in depth.
  - Pier footers may be constructed in lieu of full concrete pads (see manufacturer for specifications)
  - Lifts will be firmly bolted to concrete pad or footers
  - Drainage should be such that standing water is eliminated under lift platforms
  - Turning radius in front of machines no less than 19' (20'- 22' recommended).
- **Clearances:**
  - Clear ceiling height: 22' 6" minimum (standard unit)
  - Distance at rear of lifts to nearest wall or obstruction: 36"
  - Distance between two rows of lifts: 60-72".
- **Power requirements:**
  - 220V, 40 amp, 3-phase for each hydraulic power pack unit
  - Each power pack unit operates up to 20 lifts depending on configuration and layout
  - Individual lifts are operated by 24 VDC (low voltage)
  - Power pack units include an internal heater
- **Loadings:** There are no uplifting loads on the structure. All loading is downward and the center of gravity is located within the lift structure. Base Plate loading is below AISC allowable standards. When operated at full capacity as a stand-alone unit, the base plate loading is 17 psi (4284 lbs on base plate). When operated as a double unit in a row, the base plate loading is 26 psi (6552 lbs on base plate)